



MTD Series

MIXED FLOW IN-LINE DUCT FAN



Mixed Flow In-Line Duct Fan – MTD Series



- Specifically designed for direct connection with industrial circular ducting of standard diameter.
- Incorporate a powerful motor which is factory matched to a mixed flow impeller.
- Delivers high airflow performance with minimum noise generation and high static pressure typically found in ducted ventilation systems.
- Model 200 and below are manufactured in tough reinforced plastic, while models 250 & 315 in steel casing. All models are finished in tough epoxy-polyester paint coating.
- Impeller blades of model 200 & below are moulded in tough ABS plastic, models 250 & 315 are constructed from pressed galvanised sheet steel.
- Easy installation and maintenance - support brackets allow the motor and impeller assembly to be fitted or removed without dismantling the adjacent ducting.
- Fitted with direct connection two speed motors as standard with thermal overload protection. All motors are suitable for speed control regulation using electronic or auto-transformer.
- Max. operating temperature +40 °C.



Kruger Ventilation Industries Asia Co., Ltd certifies that the **MTD series** shown herein is licensed to bear the AMCA Seal. The ratings shown are based on tests and procedures performed in accordance with AMCA publication 211 and AMCA publication 311 and comply with the requirements of the AMCA Certified Ratings Program. Models MTD 100/2-6 and MTD 125-6 are not licensed by AMCA international

Dimension

MTD 100/1

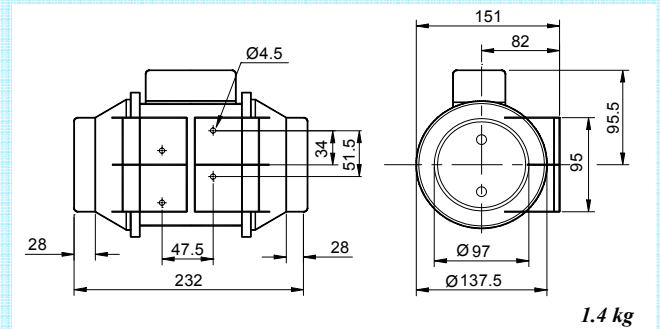

MTD 100/2 - 315

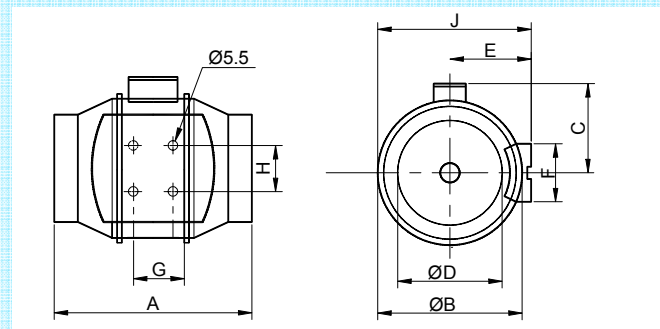

Model	A	ØB	C	ØD	E	F	G	H	J	kg
MTD 100/2	303	176	115	97	100	90	80	60	188	2.0
MTD 100/2-6	303	176	115	97	100	90	80	60	188	2.0
MTD 125	258	176	115	123	100	90	80	60	188	2.0
MTD 125-6	258	176	115	123	100	90	80	60	188	2.0
MTD 160	295	200	127	157	112	130	80	60	212	4.9
MTD 200	302	217	141	198	124	140	100	94	232.5	4.9
MTD 250	386	272	192	248	155	168	145	140	291	9.4
MTD 315	450	336	224	312	188	210	182	178	356	14.0

All dimensions in mm.

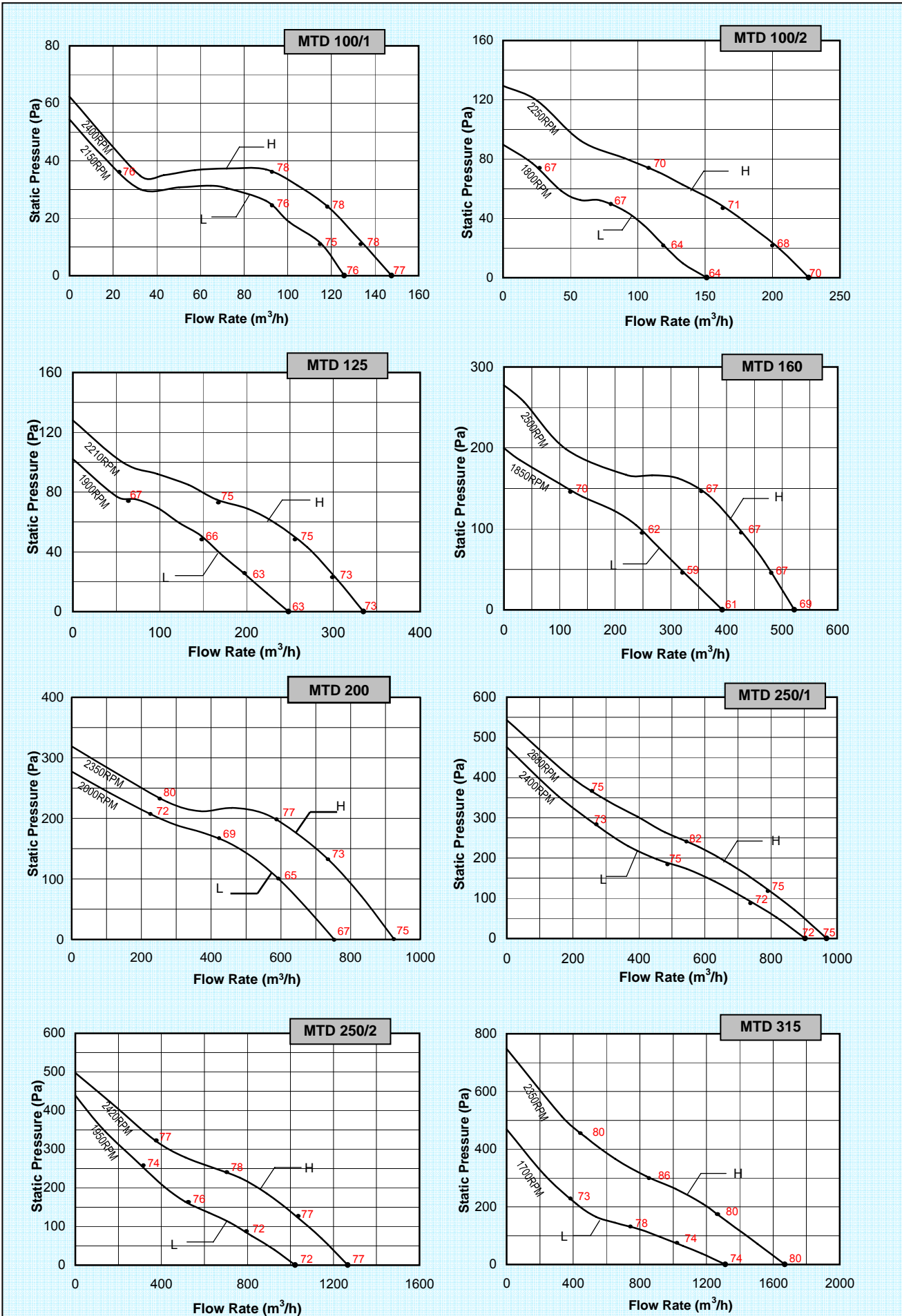

- Speed (RPM) shown is nominal. Performance is based on actual speed of test.
- Performance ratings do not include the effects of appurtenances (accessories).
- Values shown are fan inlet Lw(A) sound power level for installation type D: ducted inlet, ducted outlet. Ratings include the effect of duct and correction.
- The A-weighted sound ratings shown have been calculated per AMCA International Standard 301.

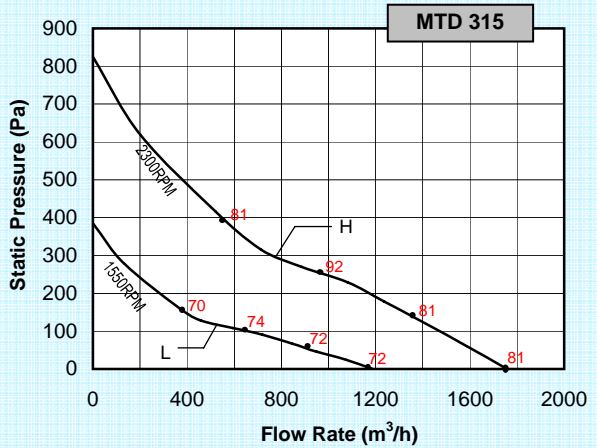
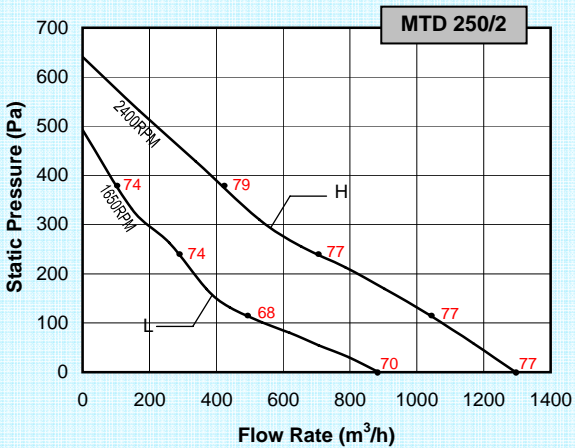
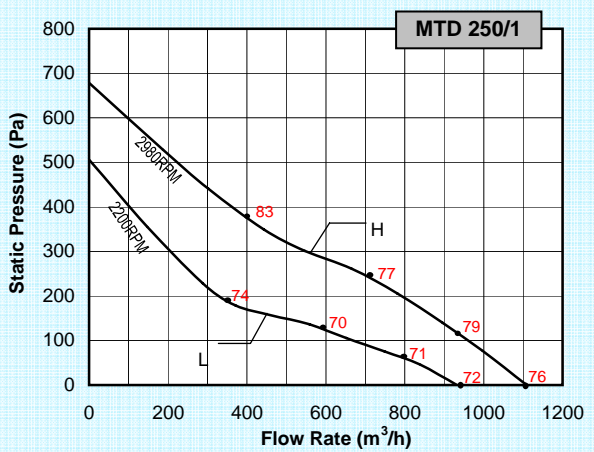
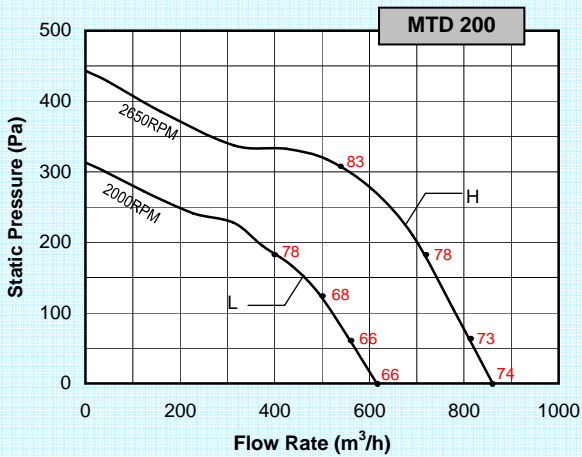
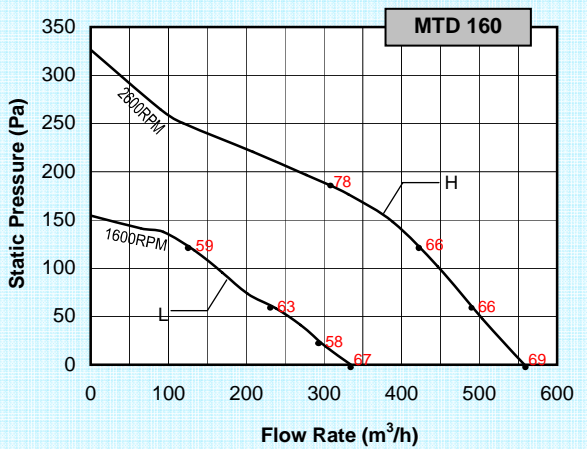
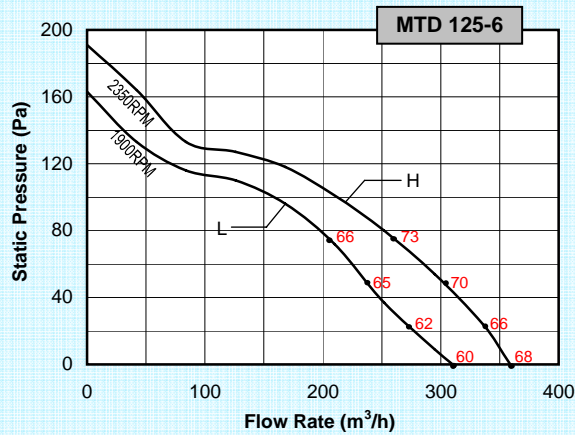
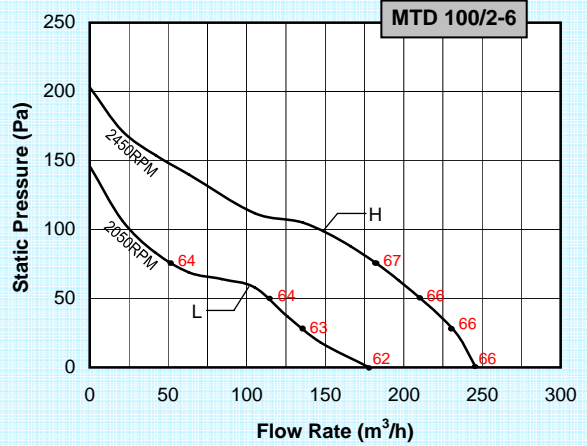
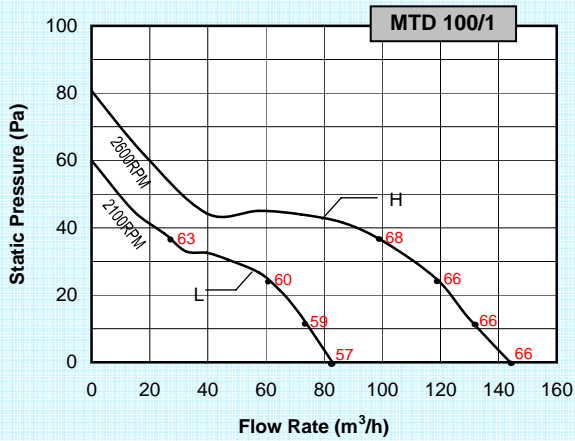

- Speed (RPM) shown is nominal. Performance is based on actual speed of test.
- Performance ratings do not include the effects of appurtenances (accessories).
- Values shown are fan inlet Lw(A) sound power level for installation type D: ducted inlet, ducted outlet. Ratings include the effect of duct and correction.
- The A-weighted sound ratings shown have been calculated per AMCA International Standard 301.
- MTD 100/2-6 and MTD 125-6 are not licensed by AMCA.

Technical Data										
Model	Max Q m ³ /h	Power W	Motor Protection	Phase	N° Pole	Hz	Max Amp	Insulation Class	dB (A) at 3m	RPM
MTD 100/1	148 / 125	33 / 20	IP44	1	2	50	0.25 / 0.15	B	58 / 56	2400 / 2150
	145 / 85	31 / 21	IP44	1	2	60	0.18 / 0.13	B	45 / 37	2600 / 2100
MTD 100/2	225 / 150	44 / 27	IP44	1	2	50	0.26 / 0.18	B	50 / 44	2250 / 1800
MTD 100/2-6	250 / 185	55 / 37	IP44	1	2	60	0.26 / 0.18	B	46 / 42	2450 / 2050
MTD 125	335 / 250	49 / 33	IP44	1	2	50	0.37 / 0.26	B	52 / 42	2210 / 1900
MTD 125-6	360 / 300	55 / 39	IP44	1	2	60	0.37 / 0.26	B	51 / 40	2350 / 1900
MTD 160	520 / 390	55 / 48	IP44	1	2	50	0.30 / 0.22	B	48 / 41	2500 / 1850
	558 / 335	68 / 52	IP44	1	2	60	0.31 / 0.23	B	49 / 38	2600 / 1600
MTD 200	840 / 690	116 / 107	IP44	1	2	50	0.55 / 0.41	B	55 / 48	2350 / 2000
	860 / 615	170 / 109	IP44	1	2	60	0.68 / 0.51	B	54 / 46	2650 / 2000
MTD 250/1	970 / 905	130 / 101	IP44	1	2	50	0.65 / 0.39	B	54 / 51	2680 / 2400
	1110 / 932	180 / 135	IP44	1	2	60	0.65 / 0.39	B	56 / 52	2980 / 2200
MTD 250/2	1270 / 1020	192 / 141	IP44	1	2	50	0.72 / 0.48	B	57 / 52	2420 / 1950
	1295 / 885	257 / 162	IP44	1	2	60	1.00 / 0.67	B	57 / 50	2400 / 1650
MTD 315	1670 / 1315	283 / 175	IP44	1	2	50	1.30 / 0.90	B	59 / 53	2350 / 1700
	1757 / 1188	352 / 186	IP44	1	2	60	1.50 / 1.00	B	60 / 52	2300 / 1550

- Speed (RPM) shown is nominal. Performance is based on actual speed of test.
- Performance ratings do not include the effects of appurtenances (accessories).
- dB(A) at 3m with ducted inlet and outlet at free field conditions. dB(A) is not licensed by AMCA International.
- MTD 100/2-6 and MTD 125-6 are not licensed by AMCA.

Accessories

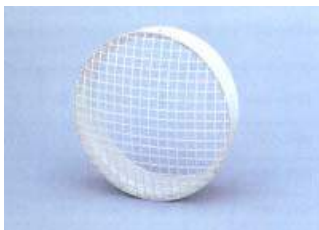

Grilles

Mounted at the inlet or outlet of the fan, the grille prevents the entry of any foreign objects.



Rectangular Duct Adapters

The adapter enables the MTD fan to be connected to rectangular ducting



Back-Draft Shutter

Mounted at the outlet of the MTD fan, the shutter prevents the air re-circulating when the fan is not in use.